

Titan 16RX 300W BEAM Light



USER MANUAL



Please read over this manual before operation the light

CONTENTS

| | |
|---|-----|
| Chapter 1 Installation and attention..... | 1 |
| 1.1 Maintenance..... | 1 |
| 1.2 Statement..... | 1 |
| 1.3 Safety Precaution..... | 1 |
| 1.4 Product Instruction..... | 1 |
| 1.5 Cable connection□DMX□..... | 2 |
| 1.6 Rigging (Optional)..... | 2 |
| Chapter 2 Panel operation..... | 4 |
| 2.1 Brief..... | 4 |
| 2.2 Operation..... | 4 |
| 2.2.1 Operate light with touch or KEY..... | 4 |
| 2.2.2 Parameter value setting..... | 4 |
| 2.2.3 Boolean parameter setting..... | 4 |
| 2.2.4 Sub Menu□Parameter□..... | 5 |
| 2.3 Operation and parameter instruction..... | 5 |
| 2.3.1 ADDR--> Address: Set DMX Address..... | 6 |
| 2.3.2 MODE--> WorkMode: Set Light work mode..... | 6 |
| 2.3.3 DISP-->DISPLAY: Set display..... | 7 |
| 2.3.4 TEST--> TestMode..... | 7 |
| 2.3.5 ADVA-->Advanced: Set light run parameter..... | 8 |
| 2.3.6 STAT-->Status: View status..... | 9 |
| Chapter 3 Channel description..... | 10 |
| 3.1 Channel table..... | 10 |
| 3.2 Channel Detail..... | 11□ |
| 3.2.1 COLOR Detail..... | 12□ |
| 3.2.2 GOBO Detail..... | 12□ |

Chapter 1 Installation and attention

1.1 Maintenance

- To reduce the risk of electrical shock or fire, do not expose this unit to rain or moisture.
- Intermittently using will extend this item's service life.
- Please clear the fan ,fan net , and optical lens in order to keep good work state.
- Do not use the alcohol or any other organic solvent to wipe the shell.

1.2 Statement

The product has perfect performance and integrity packing. All users should be strictly complying with the warning and operating instructions as stated. Or we aren't in charge of any result by misusing. Any damage resulting by misuse is not within the Company's warranty. Any fault or problem caused by neglecting the manual is also not in the charge of dealers.

Note: All information is subject to change without prior notice.

1.3 Safety Precaution

- In order to guarantee the product's life, please don't put it in the damp places or even the environment over 60degrees.
- Always mount this unit in safe and stable matter.
- Install or dismantle should operate by professional engineer.
- Using lamp □the change rate of power voltage should be within±10% □If the voltage is too high□it will shorten the light's life; If it's not enough, will influence the effect.
- Please restart it 20 minutes later after turning off light , until full-cooling. Frequent switching will reduce the life span of lamps and bulbs; intermittent using will improve the life of bulbs and lamps.
- In order to make sure the product is used well, please read the Manual carefully.

1.4 Product Instruction

- lamp: MSD 295w (life:2200 hours Color temperature: 8000K)
- Channel mode:16 DMX512 Channel
- Pan scan□540°(16bit) Electric correction
- Tilt scan□270° (16bit) Electric correction
- Amazing dot matix, four tact switch, 180° turning show
- Color wheel: one color wheel, 14 kinds of color chips in one color wheel
- Gobo: 14 gobos
- Effect Wheel: Rotation 48 prism+8 prism, effect move , frost
- 0-100% mechanical dimming, mechanical dimming and free dimming available.

- strobe macro control available.
- Lens optical system achanical fouce .beam angle 0□4°
- Over heat protection
- Power Input: 100-240V□50/60Hz
- Power Dissipation□350W
- IP level :IP20
- [Magnetic ballast](#) and AC/Dc power supply
- Product Size□523×337×511mm
- Packing Size: 635X440X725
- Net weight□19.5KG

1.5 Cable connection□DMX□

Use a cable conforming to specifications EIA RS-485: 2-pole twisted, shielded, 120Ohm characteristic impedance, 22-24 AWG, low capacity. Do not use microphone cable or other cable with characteristics differing from those specified. The end connections must be made using XLR type 3 or 5-pin male/female connectors. A terminating plug must be inserted into the last projector with a resistance of 120Ohm (minimum 1/4 W) between terminals 2 and 3.

IMPORTANT: The wires must not make contact with each other or with the metal casing of the connectors. The casing itself must be connected to the shield braid and to pin 1 of the connectors.

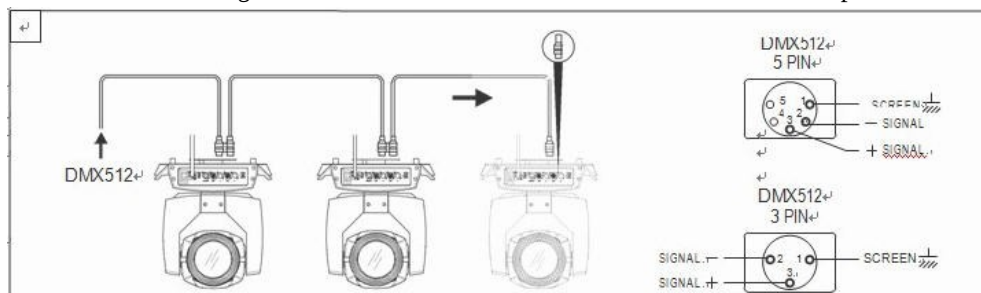

Figure 1 DMX Cable connection

1.6 Rigging (Optional)

This equipment can be positioned and fixed by clamp in every direction of the stage. Locking system makes it easy to fasten to the bracket.

Attention! Two clamps is needed to fix the equipment. Every clamp is locked by fastener of 1/4 kind. Fastener can only be locked clockwise.

Attention! Fasten a safety string to the additional hole of side aluminum piece. The secondary accessory can not hang on the delivery handle. Nip the equipment on bracket.

- Check if rigging clamp (not including the one inside) damaged or not? If stand ten times weight as the equipment. Make sure the architecture can stand ten times weight as all the equipments, clamps, wirings and other additional fixtures.
- Screws for clamping must be fixed firmly. Take one M12 screw (Grade 8.8 or higher) to

clamp bracket, and then screw the nuts.

- Level the two hanging points at the bottom of clamp. Insert fastener to the bottom, lock the two levers by 1/4 rotating clockwise; then install another clamp.
- Install on safety string which stands at least ten times weight as equipment. Terminal of the accessory is designed for clamps.
- Make sure pan/tilt lock unlocked or not. Keep the distance more than 1M from equipment to flammable material or lighting source.

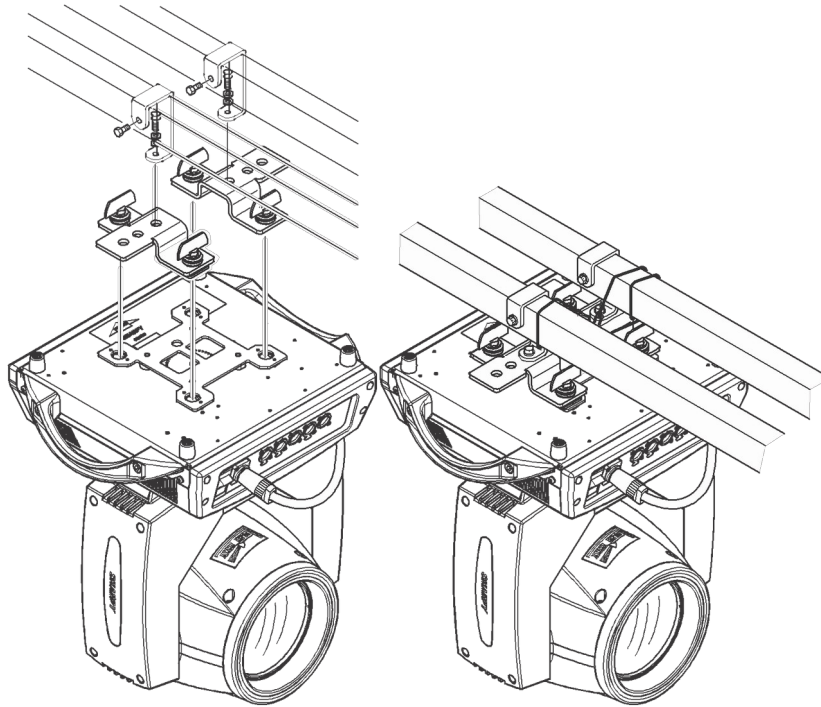

Figure 2 Installation

Chapter 2 Panel operation

2.1 Brief

The light panel diagram show as Figure 3, Left area is TFT Displayer, support touch, and right area is KEY, both of touch and KEY can operate light and setting.

Display & operation just like 'Android operation system', touch the item will set or modify setting.

Note: Prevent damage the touch or TFT displayer, Can not use sharp objects chick displayer.

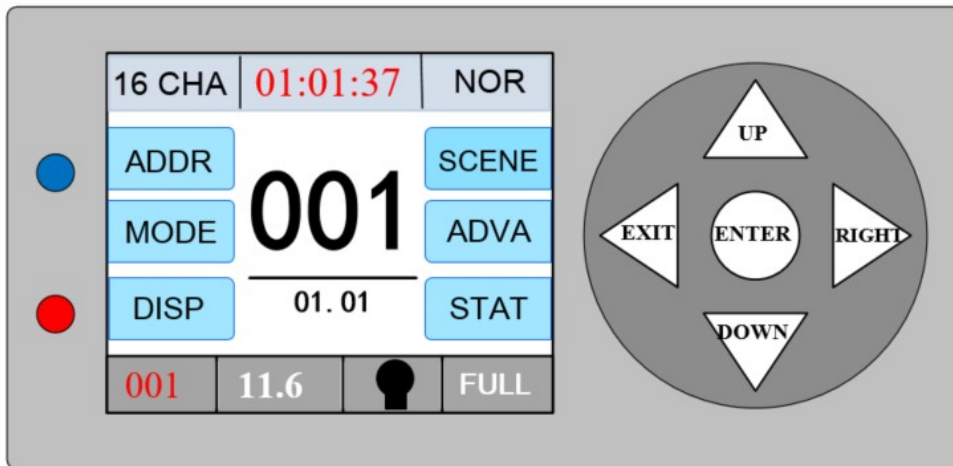

Figure 3 Panel diagram

2.2 Operation

2.2.1 Operate light with touch or KEY

- The left area is TFT Displayer and touch, chick item or value with finger will to complete operation of set light setting(parameters) or view light state.
- The area on the right hand side is 4 KEY, As auxiliary input interface, if disable touch function,, the KEYr can been choose to set the parameter.

2.2.2 Parameter value setting

When the selected item is value need to be modified, the dialog shown in Figure 4 will popup.

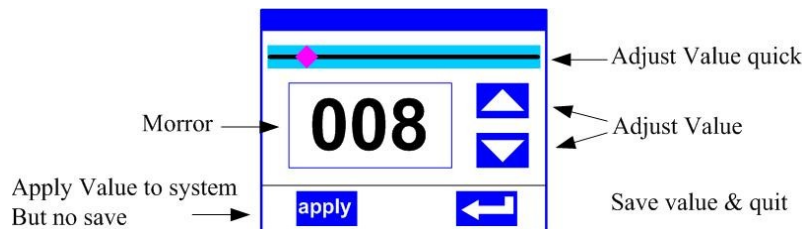

Figure 4 Dialog of value setting

- **Modify value** Can quickly modify value via pull the slider to the desired position, or click the button of 'up' or 'down' whit finger on the right side to set the exact desired value, another way is roll encoder on the right hand side of panel.
- **Apply value** When Value had been modified, Then press the bottom of 'apply' in the left corner to apply to the light, but hav't saved
- **Save Value** Any time, click on the lower right corner of the "OK" button, the setting will be saved into internal memory.

2.2.3 Boolean parameter setting

- when the selected parameters is a Boolean value (such as ON or OFF), can directly modify setting by click corresponding item, the setting will be saved right now.
- When the parameter is a key item, click corresponding item, a dialog shown in Figure 5 will be popup ask for the confirm. Click 'sure' to confirm.

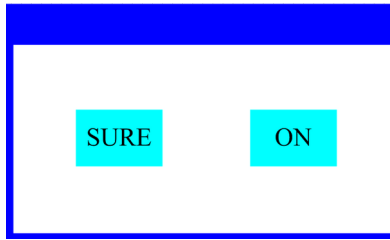

Figure 5 Dialog of confirm

2.2.4 Sub Menu Parameter

Click item of main menu, enter corresponding sub menu, shown in Figure 6, total 6 sub menu, includes class of parameter and status:

- ADDRESS Set light DMX address.
- WORKMOD Set light work mode, master or slave mode when in auto run mode.
- DISPLAY Set display parameter, eg. select language.
- TEST Used for test light, modify DMX channel data to test function the corresponding function of reference channel function table.
- ADVANCE Set light running parameter.
- STATUS view light current status.



Figure 6 Parameter menu

2.3 Operation and parameter instruction

Via following operation, enter sub menu(parameter menu) shown in Figure 6

- In main menu, click 1/6 function button into corresponding parameter menu.
- In sub menu(page), click main item on the left side of display, can shift to corresponding sub menu(page) quickly.

2.3.1 ADDR--> Address: Set DMX Address

Click and select the "ADDR", can enter the page of DMX address setting, range from 1 to 512, the address code shouldn't is not greater than (512- channels quantity), otherwise the light will not be controlled. Following is the operation:

Enter the page of DMX address, as shown in Figure 7, click the blank area in right side of display will pop-up diglog as in Fig. 4, modify value, then click 'ENTER' to confirm and save DMX address code.

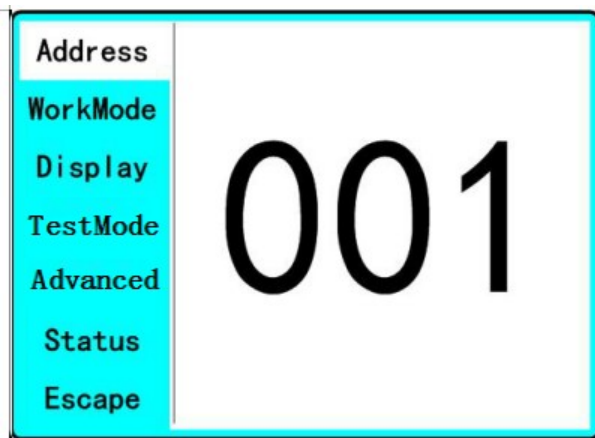

Figure 7 page of DMX Address

2.3.2 MODE--> WorkMode: Set Light work mode

Enter the page of 'WorkMode' as shown in Figure 8 and modify setting. Can set light work mode, control lamp and DMX channel mode.

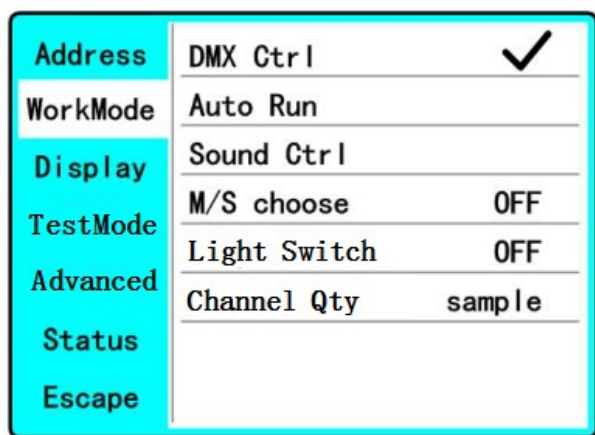

Figure 8 page of work mode

- ◆ **DMX Ctrl:** Choose to set DMX Mode,
- ◆ **Auto Run:** Choose to set Auto Mode,
- ◆ **Sound Ctrl:** Choose to set Sound Mode,
- ◆ **M/S Choose:** Available just in 'AUTO RUN' or 'SOUND Ctrl' mode.
ON--> Master. (Data will be send to other slave lamp immediately.)
OFF--> Slaver.(NOT send data to other lamp via DMX Cable).(Default)
- ◆ **Light Switch:**
ON--> Turn on the light,
OFF--> Turn off the light.

◆ **Channel Qty:** Light support 2 DMX Channel mode: sample or extend

Simple --> 16CH.(Default)

Expand--> 20CH(or null).

2.3.3 DISP-->DISPLAY: Set display

Light support 2 language, rotation display Enter page as shown in Figure9 to set parameter following:

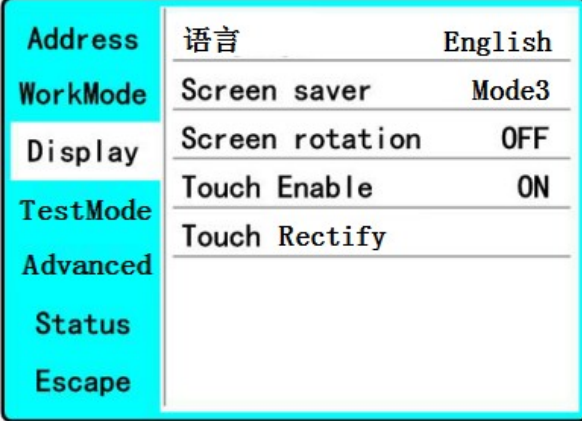

| | | |
|----------|-----------------|---------|
| Address | 语言 | English |
| WorkMode | Screen saver | Mode3 |
| Display | Screen rotation | OFF |
| TestMode | Touch Enable | ON |
| Advanced | Touch Rectify | |
| Status | | |
| Escape | | |

Figure9 page of display

◆ **Language:** English / 语言.

◆ **Screen Saver:** when panel is idle(these is no operation in 10 second), displayer will enter saver status.

OFF--> No screen saver.

Mode1--> Power-saving mode, turn off the display.

Mode2--> Displays the current address.

Mode3--> Displays the icon and the current working mode.(Default)

◆ **Screen Rotion: To turning display.**

ON--> Normal display.(Default)

OFF--> 180° turning display.

◆ **Touch enable** Disable or enable touch function,.

ON--> Enable touch function.(Default)

OFF--> Dosable touch function.

◆ **Touch adjust** Adjust touch function. Normally, not enter this item.

2.3.4 TEST--> TestMode

Enter the page as shown in Figure 10, Light will into test mode, in this mode, the light does not receive the data for DMX controller.:

| | | |
|-----------------|--------|-----|
| Address | PAN | 000 |
| WorkMode | TILT | 000 |
| Display | FOCUS | 000 |
| TestMode | COLOR | 000 |
| | GOBO | 000 |
| Advanced | PRISM | 000 |
| Status | FROST | 000 |
| Escape | STROBE | 000 |

Figure 10 page of Test

- ◆ **PAN:** range for 0 to 255;
- ◆ **TILT:** range for 0 to 255;
- ◆ **FOCUS:** range for 0 to 255;
- ◆ **COLOR:** range for 0 to 255;
- ◆ **GOBO:** range for 0 to 255;
- ◆ **PRISM:** range for 0 to 255;
- ◆ **FROST:** range for 0 to 255;□
- ◆ **STROBE:** range for 0 to 255;

2.3.5 ADVA-->Advanced: Set light run parameter

Enter the page as shown in Figure 10, set the parameter of light:

| | | |
|-----------------|-----------------|----------|
| Address | PAN Inset | OFF |
| WorkMode | TILT Inset | OFF |
| Display | P/T Rectify | ON |
| TestMode | PAN Offset | 010 |
| | TILT Offset | 010 |
| Advanced | Lamp when | Power ON |
| Status | Data hold | OFF |
| Escape | Factory Setting | |

Figure 11 page of run parameter

- ◆ **Pan Invert: Reverse PAN move**
OFF--> Pan Normal move.(Default)
ON--> Reverse PAN move.
- ◆ **Tilt Invert: Reverse TILT move**
OFF--> Tilt Normal move.(Default)
ON--> Reverse Tilt move.
- ◆ **P/T Rectify: Disable or enable position rectify function.**
OFF--> Disable P/T rectify
ON--> Enable P/T rectify-(Default)
- ◆ **Pan Offset:** Set PAN original position. **Default: 10**
- ◆ **Tilt Offset:** Set TILT original position. **Default: 10**
- ◆ **Lamp when:**

PowerON--> Turn on the lamp when power on.(Default)

RstDone--> Turn on the lamp after reset.

Manual--> Manually turn on the lamp.

◆ **Data hold:**

OFF--> When no DMX signal,return to middle position.(Default)

ON--> When no DMX signal,stop in the final position.

◆ **Factory Setting:** Restore all parameter to factory setting.

2.3.6 STAT-->Status: View status

Enter the page as shown in Figure 12:

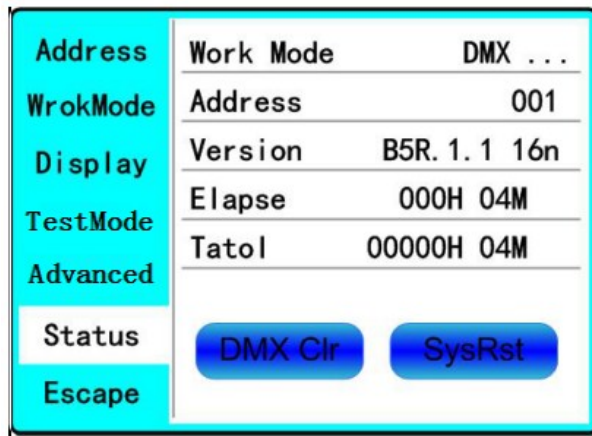
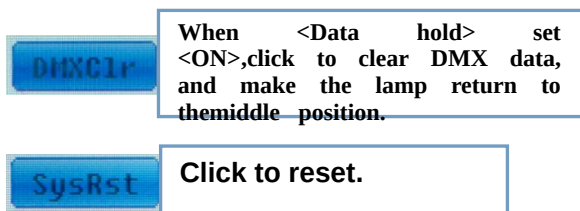

Figure 12 page of status

- ◆ **Work Mode:** Show the current working mode.
- ◆ **Address:** Show the current address.
- ◆ **Version:** Show the version of the lamp.
- ◆ **Elapse:** Working hours after turn on.
- ◆ **Tatol:** Cumulative hours of operation



Chapter 3 Channel description

3.1 18 Channel table

Table 1 Channel brief

| 18CH | 22CH | Name | number | describe |
|---------|-----------------|--------------|--------|----------------|
| CH1 | CH1 | Color | 0-4 | White |
| | | | 5-9 | White+Color1 |
| | | | 10-14 | Color1 |
| | | | 15-19 | Color1+Color2 |
| | | | 20-24 | Color2 |
| | | | 25-29 | Color2+Color3 |
| | | | 30-34 | Color3 |
| | | | 35-39 | Color3+Color4 |
| | | | 40-44 | Color4 |
| | | | 45-49 | Color4+Color5 |
| | | | 50-54 | Color5 |
| | | | 55-59 | Color5+Color6 |
| | | | 60-64 | Color6 |
| | | | 65-69 | Color6+Color7 |
| | | | 70-74 | Color7 |
| | | | 75-79 | Color7+Color8 |
| | | | 80-84 | Color8 |
| | | | 85-89 | Color8+Color9 |
| | | | 90-94 | Color9 |
| | | | 95-99 | Color9+Color10 |
| 100-104 | Color10 | | | |
| 105-109 | Color10~Color11 | | | |
| 110-114 | Color11 | | | |
| 115-119 | Color11+Color12 | | | |
| 120-124 | Color12 | | | |
| 125-129 | Color12+Color13 | | | |
| 130-134 | Color13 | | | |
| 135- | Color13+Color14 | | | |

| | | | | |
|---------|-------------------------------------|---------------|---------|-------------------------------------|
| | | | 139 | |
| | | | 140-144 | Color14 |
| | | | 145-149 | Color14+White |
| | | | 150-200 | Forwards rainbow from fast to slow |
| | | | 201-255 | Backwards rainbow from slow to fast |
| CH2 | CH2 | Strobe | 0-3 | Close |
| | | | 4-103 | Fadeout slow to fast |
| | | | 104-107 | Open |
| | | | 108-207 | Free Strobe slow to fast |
| | | | 208-212 | Open |
| | | | 213-251 | Pulse Strobe slow to fast |
| | | | 252-255 | Open |
| CH3 | CH3 | Dimmer | 0~255 | Dimmer intensity from 0% to 100% |
| CH4 | CH4 | Gobo | 0-4 | White |
| | | | 5-9 | Gobo1 |
| | | | 10-14 | Gobo2 |
| | | | 15-19 | Gobo3 |
| | | | 20-24 | Gobo4 |
| | | | 25-29 | Gobo5 |
| | | | 30-34 | Gobo6 |
| | | | 35-39 | Gobo7 |
| | | | 40-44 | Gobo8 |
| | | | 45-49 | Gobo9 |
| | | | 50-54 | Gobo10 |
| | | | 55-59 | Gobo11 |
| | | | 60-64 | Gobo12 |
| | | | 65-69 | Gobo13 |
| | | | 70-125 | Forwards rainbow from fast to slow |
| | | | 126-130 | Stop |
| 131-190 | Backwards rainbow from slow to fast | | | |
| 191- | Gobo1 Shake □ Slow to fast | | | |

| | | | | |
|-----|-----|------------------------|---------|-------------------------------------|
| | | | 195 | |
| | | | 196-200 | Gobo2 Shake□Slow to fast |
| | | | 201-205 | Gobo3 Shake□Slow to fast |
| | | | 206-210 | Gobo4 Shake□Slow to fast |
| | | | 216-220 | Gobo6 Shake□Slow to fast |
| | | | 221-225 | Gobo7 Shake□Slow to fast |
| | | | 226-230 | Gobo8 Shake□Slow to fast |
| | | | 231-235 | Gobo9 Shake□Slow to fast |
| | | | 236-240 | Gobo10 Shake□Slow to fast |
| | | | 241-245 | Gobo11 Shake□Slow to fast |
| | | | 246-250 | Gobo12 Shake□Slow to fast |
| | | | 251-255 | Gobo13 Shake□Slow to fast |
| CH5 | CH5 | Prism | 0-31 | Empty |
| | | | 32-63 | Insert Prism 1 |
| | | | 64-95 | Insert Prism 2 |
| | | | 96-127 | Insert Prism 3 |
| | | | 128-159 | Insert Prism 4 |
| | | | 160-191 | Insert Prism 1+2 |
| | | | 192-223 | Insert Prism 1+3 |
| | | | 224-255 | Insert Prism 1+4 |
| CH6 | CH6 | Prism 1.Rot | 0-127 | Prism position |
| | | | 128-190 | Forwards rainbow from fast to slow |
| | | | 191-192 | Stop |
| | | | 193-255 | Backwards rainbow from slow to fast |
| CH7 | CH7 | Prism wheel.Rot | 0-127 | Prism position |
| | | | 128- | Forwards rainbow from fast to slow |

| | | | | |
|------|---------|--------------------------|---------------------------|-------------------------------------|
| | | | 190 | |
| | | | 191-192 | Stop |
| | | | 193-255 | Backwards rainbow from slow to fast |
| CH8 | CH8 | Colorful/ Frost | 0-127 | empty |
| | | | 128-190 | Frost |
| | | | 191-255 | colorful |
| CH9 | CH9 | Zoom | 0~255 | Zoom Large to small |
| CH10 | CH10 | PAN | 0~255 | Pan movement by 540 |
| CH11 | CH11 | TILT | 0~255 | Tilt movement by 270 |
| CH12 | CH12 | PAN fine | 0~255 | Fine control of pan movement |
| CH13 | CH13 | TILT fine | 0~255 | Fine control of tilt movement |
| CH14 | CH14 | XY Speed | 0~255 | Macro function |
| CH15 | CH15 | Reset | 0-25 | empty |
| | | | 26-76 | Small motor reset |
| | | | 77-127 | Big motor reset |
| | 240-255 | | Reset all(over 5 seconds) | |
| CH16 | CH16 | Lamp control | 0-9 | empty |
| | | | 10-100 | Lamp off □Over 3 seconds□ |
| | | | 101-255 | Lamp on □Over 3 seconds□ |
| | CH17 | XY Speed | 0~255 | Fast to slow |
| | CH18 | Color wheel speed | 0-255 | Fast to slow |
| | CH19 | Prism speed | 0-255 | Fast to slow |
| | CH20 | Gobo wheel speed | 0-255 | Fast to slow |
| CH17 | CH21 | Led Strip | 0-255 | Effect Show |
| CH18 | CH22 | Led Strip Speed | 0-255 | Effect Show Speed |

AUVI LIGHTS LLC

1901 NORTHWESTH HWY
STE 200

GARLAND, TX 75041

972-290-0595

sales@auviprod.com

www.auviprod.com